

8 7 6 5 4 3 2 1

THE INFORMATION CONTAINED IN THIS DRAWING IS THE SOLE PROPERTY OF ANDERSON POWER PRODUCTS. ANY REPRODUCTION IN PART OR WHOLE WITHOUT THE WRITTEN PERMISSION OF ANDERSON POWER PRODUCTS IS PROHIBITED.

DATE	7/17/01
BY:	CMS
DESCRIPTION OF CHANGES	ECRN 13410- ADD PANEL CUTOUT DIMS.
REV	1

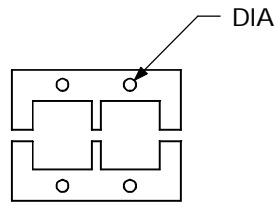

2 OR 4 POLE

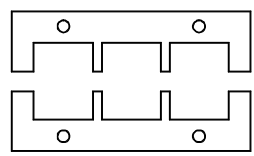

3 OR 6 POLE

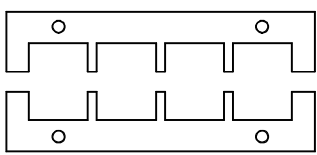

4 POLE

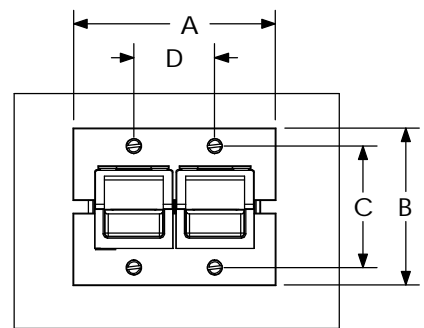

PANEL CUTOUT DIMENSIONS

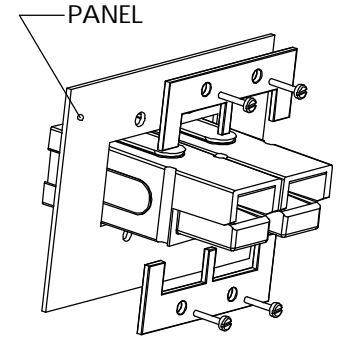
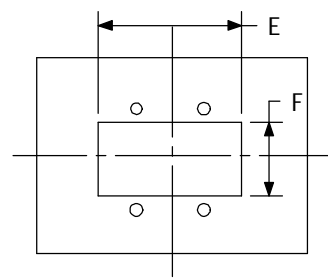

TABLE OF MOUNTING CLAMPS FOR PP75-PP180

CAT. NO.	PP Series	# of Poles	A		B		C		D		DIA		E		F	
			IN	MM	IN	MM	IN	MM	IN	MM	IN	MM	IN	MM	IN	MM
1463G1	PP75	2	1.62	41.1	1.36	34.5	1.06	26.9	1.25	31.7	.16	4.0	1.38	35.1	.75	19.0
		4	1.62	41.1	1.98	50.3	1.68	42.7	1.25	31.7	.16	4.0	1.38	35.1	1.38	35.1
1463G2	PP75	3	2.25	57.2	1.36	34.5	1.06	26.9	1.88	47.8	.16	4.0	2.00	50.8	.75	19.0
		6	2.25	57.2	1.98	50.3	1.68	42.7	1.88	47.8	.16	4.0	2.00	50.8	1.38	35.1
1464G1	PP120	2	2.38	60.5	1.88	47.8	1.50	38.1	1.75	44.4	.16	4.0	1.88	47.8	1.00	25.4
		4	2.38	60.5	2.76	70.1	2.38	60.5	1.75	44.4	.16	4.0	1.88	47.8	1.88	47.8
1464G2*	PP120	3	3.25	82.6	1.88	47.8	1.50	38.1	2.62	66.5	.16	4.0	2.75	70.0	1.00	25.4
1465G1*	PP180	2	2.81	71.4	2.18	55.4	1.68	42.7	1.12	28.4	.19	4.8	2.38	60.5	1.25	31.8
1465G2*	PP180	3	3.97	100.8	2.18	55.4	1.68	42.7	2.25	57.2	.19	4.8	3.50	88.9	1.25	31.8

* SEE NOTE 2

- NOTES:
1. MOUNTING CLAMPS SOLD IN PAIRS, SCREWS NOT INCLUDED
 2. PP120 3- POLE AND PP180 2 AND 3 POLE MOUNTING CLAMPS ARE FOR SINGLE ROWS ONLY.

ITEM NO.	PART OR IDENTIFYING NO.	NOMENCLATURE OR DESCRIPTION	MATERIAL SPECIFICATION	QTY REQD	
COPYRIGHT 1999 ANDERSON POWER PRODUCTS. ALL RIGHTS RESERVED. UNAUTHORIZED REPRODUCTION HEREBY PROHIBITED.					
DIMENSIONS ARE IN INCHES DIMENSIONS IN PARENTHESES [] ARE IN MILLIMETERS		CAD GENERATED DRAWING, DO NOT MANUALLY UPDATE	ANDERSON POWER PRODUCTS MOUNTING CLAMPS FOR PP75- PP180		
TOLERANCES ARE: 2PL- ±.02 [±.5]		APPROVALS			DATE
MATERIALS: <i>AL- .09" THK</i>		DRAWN			CMS 11/1/99
FINISH <i>NONE</i>		CHECKED			DJD 11/3/99
NEXT ASSY	USED ON	RESP ENG	UFN 11/4/99	SIZE	
APPLICATION	DO NOT SCALE DRAWING	MFG ENG	CHB 11/4/99	A	
		QUAL ENG	RPO 11/4/99	SCALE	
				NONE	
				CADFILES/01137	
				SHEET 1 OF 1	
				REV. 1	
				SPECIFICATION: 114207S1	

8 7 6 5 4 3 2 1